

Modicon Twido

<http://www.modicon.com/>

HMI Setting:

Parameters	Recommend	Option	Notes
PLC type	Modbus RTU	Modbus RTU Ext.pds Modbus RTU (485 2w) Modbus RTU (RS232)	The pds driver support Extended Address mode.
Com port	RS485	RS232/RS485	Must match the PLC's port setting.
Baud rate	19200	19200	Must match the PLC's port setting.
Parity bit	None	Even, Odd, None	Must match the PLC's port setting.
Data Bits	8	8	Must set 8 for RTU mode
Stop Bits	1	1	Must set 8 for RTU mode
HMI Station No.	0	0-255	Does not apply to this protocol.
PLC Station No.	1	0-247	Must match the PLC's port setting.

PLC Setting:

Communication mode	19200, None, 8, 1
Select	Modbus RTU Slave

Device address:

Bit/Word	Device Type	Format	Range	Memo
B	0x or 1x	dddd	1~9999	%Mi
W	3x or 4x	dddd	1~9999	%MWi

Wiring diagram:

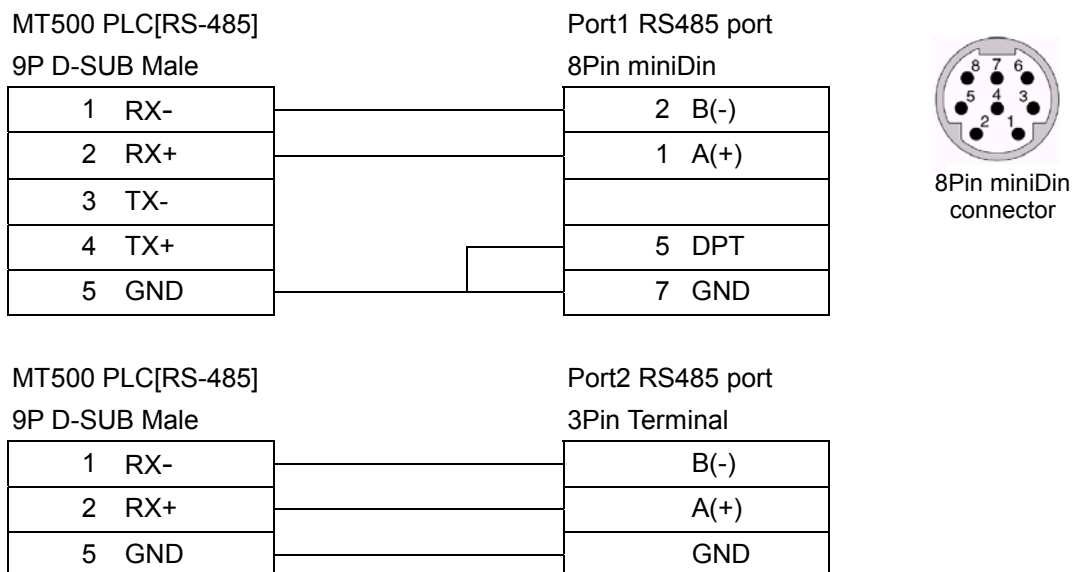

MT500 PLC[232]

9P D-SUB Female

2	TX
3	RX
5	GND

Port2 RS232

9P D-SUB Female

2	RX
3	TX
5	GND

